

HITACHI



Hitachi Refrigerator Bottom Mount

Product Code HRBN6340EXAU



Stylish Design Series

Max Fresh

Humidity is precisely controlled and condensation reduced via air channels, temperature variations minimised, so your fruit and vegetables stay crisp and fresh. Keep fruit and vegetables fresh longer.

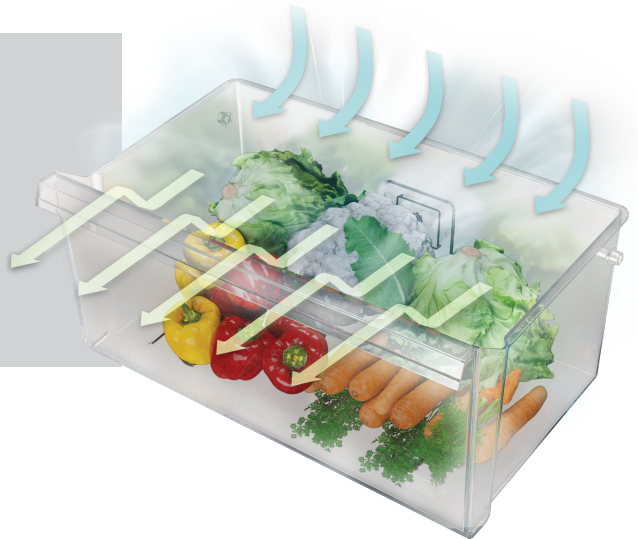

Dual Cooling

Hitachi's dual cooling technology means separate cooling systems for each compartment, maintaining ideal airflow and optimal temperatures in both the freezer and the fridge. As a result, food stays fresh for longer with no frost build-up or odour transfer.



Active Odour Filter

Active Odour filter removes odours and bacteria from the cool air circulated in your fridge, keeping all your food nice and fresh.



Mould Free Door Gasket

Thanks to Hitachi's mouldproofing treatment, the door gasket is mould-free and kept clean.

Moveable Ice Tray & Ice Box

For greater flexibility you can move the ice tray and box for more convenient and efficient use of space.



Slide out Dairy Compartment

A chiller drawer with a temperature range of 0°C - 5°C for convenient storage of your meat and dairy items.



Tempered Glass Shelves

Scratch-proof and heat-resistant, the tempered glass shelves can hold up to 100kg* each

Weight resistance of the tempered glass. Images are for illustrated purpose only.



LED Illumination

Energy-saving LED lights in the fridge compartment provide ample illumination for a clear view of the thoughtfully crafted interior.



Specification

Model	HRBN6340EXAU	
Type	Bottom Mount Freezer	
Capacity	Total Volume	323l
	Fridge Volume	233l
	Freezer Volume	90l
General / Performance	Colour	Pearl Steel
	Cooling System	Dual Cooling
	Energy Rating	3.5 Star
	Energy Consumption at 32°C (kwh/year)	321
	Noise Level	40dBA
	Climate Class	SN-T
Hygiene/Freshness	Max Fresh Crisper Compartment	●
	Active Odour Filter	●
	Mould-free door gasket	●
Fridge Compartment	Eco Mode	●
	Holiday Mode	●
	Door Open Alarm	●
	Dairy Compartment	●
	Total Cabinet Shelves	4
	Height Adjustable Shelves	3
	Tempered Glass Shelves	●
	LED Illumination	On Side Wall
Freezer Compartment	Moveable Ice Box & Ice Tray	●
	Double Twist Ice Maker	●
	Number of Freezer Drawers	3
Identification	Skus	8700000995
	EAN	8859377109395
	Warranty	5 Years Product
Dimensions (mm)	Width	600
	Depth	670
	Height	1720
Weight (Net/Gross, kg)	66 / 70	

Dimensions

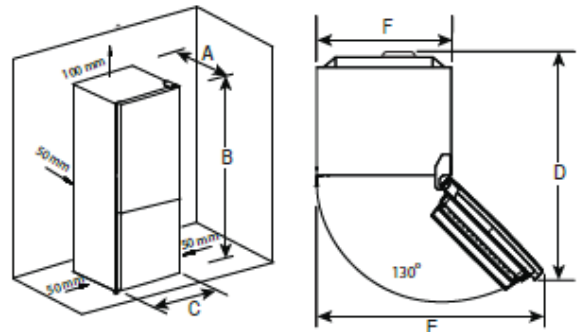

- Specifications and designs are subject to change without notice.
- Colour tone of actual products may differ from those shown.
- Feature images are for illustrative purposes only, they may not reflect the actual product.

Model	A	B	C	D	E	F
HRBN6340EXAU	670	1720	600	1038	969	600

Beko A&NZ Pty Ltd
Official Distributor of Hitachi Home Appliances

55 Blanck Street, Ormeau QLD 4208
www.hitachi-homeappliances.com/au-en